

Wheeled Conveyors

40ft (12m), 50ft (15m), 60ft (18m) & 80ft (24m)



Picture shows optional extended feedboot

Range

Model	Conveyor		Belt Width	
	FT	M	Inch	mm
RTE 4026	40	12	26	600
RTE 5030	50	15	30	750
RTE 6036S	60	18	36	900
RTE 6036H	60	18	36	900
RTE 8042L	80	24	42	1050
RTE 8042P	80	24	42	1050

Features

- Throughput up to 400tph (440 Ton)
- Manual folding head section as standard
- Site Tow-bar for relocation
- Hydraulic coupling as standard
- Radial non braking axle
- Lagged head drum
- Remote greasing to bearings
- Galvanised Legs
- Galvanised pivot plate
- Fully guarded
- Skirted feed boot
- Manual height adjustment

Advantages

- Reduce fuel consumption by up to 80%
- Eliminate / reduce need for wheel loader
- Eliminate material double handling
- Reduce noise, dust and emissions
- Higher quality end product
- Easy to transport / relocate
- Reduce Crusher / Screen idle time.
- Its portability allows it to work in confined spaces and also where heavier conveyors would find it impossible to manoeuvre.

Options

- Heavy duty belt
- Chevron belt
- Electric Drive
- Scraper upgrade
- Coupling kit for hydraulic version
- Control valve to raise / lower / start / stop
- Powered radial drive
- Diesel hydraulic Power-pack
- Feedboot liners
- Hydraulic handpump to raise and lower

Wheeled Conveyors

40ft (12m), 50ft (15m), 60ft (18m) & 80ft (24m)

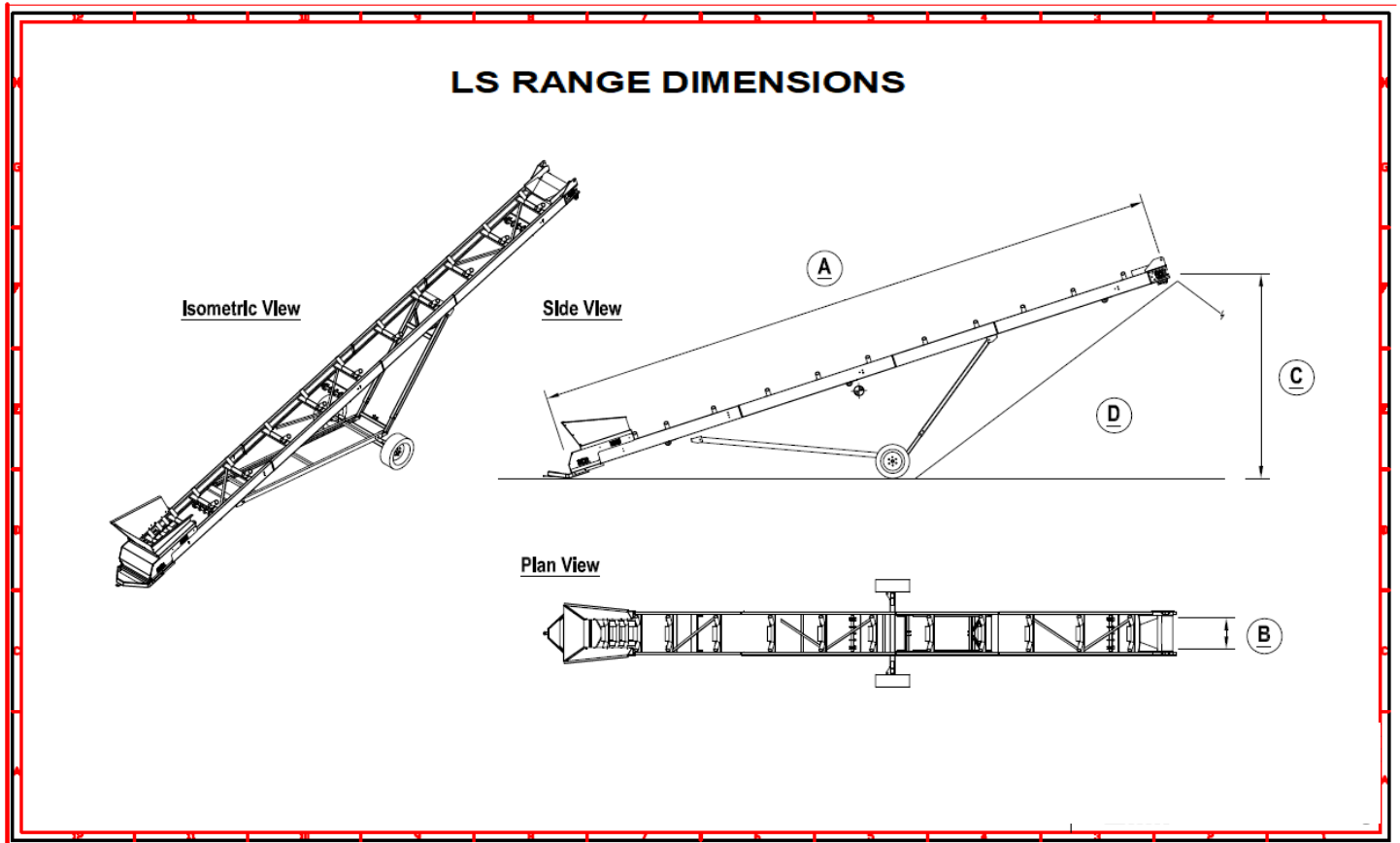

Technical Details

Model	A		B		C		D (Stockpile Capacity, Single Cone)			
	FT	M	Inch	mm	FT	M	m3	yrds3	Tonne	Ton (USA)
RTE 4026	40'	12	26"	600	15' 8"	4.8	170	220	270	300
RTE 5030	50'	15	30"	750	19'	6.22	380	500	606	670
RTE 6036S	60'	18	36"	900	22' 3"	7.22	605	792	970	1070
RTE 6036H	60'	18	36"	900	22' 3"	7.22	605	792	970	1070
RTE 8042L	80'	24	42"	1050	30'	9.2	1300	1700	2100	2315
RTE 8042P	80'	24	42"	1050	30'	9.2	1300	1700	2100	2315



sales@roktec.com.au

CRUSH | SCREEN | WASH | CONVEY | STOCKPILE